



tryggare
närvarande
nyskapande

REVISIONS				
ZONE	REV	DESCRIPTION	DATE	DRAWN
	A	EG17002	01/11'17	EDDIE

INSTRUCTION SHEET

STEP 1:

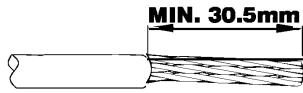

▲ U/UTP

Strip off at least 30.5 mm of jacket from end of cable.
Wire gauges : 22~24 AWG , (solid wire)
: 22~26 AWG , (stranded wire,
AWG can not mixed use.)

STEP 2:

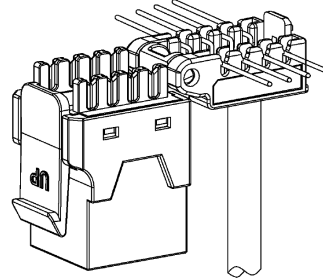

Lay the wires to the correct groove based on the color code. (T568A / T568B)

STEP 3:

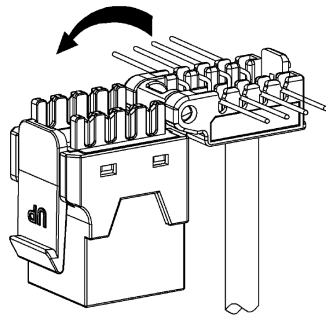

Close the cap.

STEP 4:

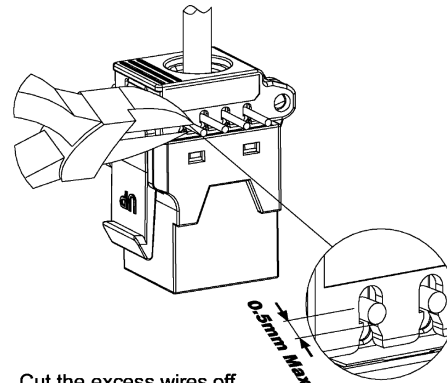

Cut the excess wires off.
The tips of the wires shall protrude no more than 0.5 mm.

STEP 5:

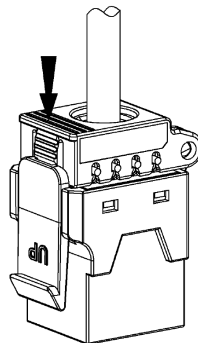

Press the cap to the latch end.

Disassemble :

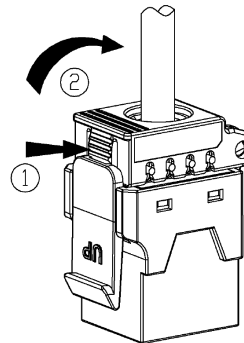

Press the latch and push up.

UNLESS OTHERWISE SPECIFIED:				PROJECT ID		ELKO	
TOLERANCES				R2101F-TMH-019EK		tryggare närvarande nyskapande	
INCH	MIL	ANGULAR		FILE	DATE	TITLE	
X ± .018	X ± 0.7	X ± .1°	X ± .5°	L4925.dwg	08/23'16	E51 402 54	
XXX ± .004	XXX ± 0.1	X ± .5°	X ± .5°	DRAWN	EDDIE	DRAWING NUMBER	PART NUMBER
						A4	L4925
							LL3A06983
						SCALE	1:1
						UNIT	mm
						SHEET	1 OF 1